



SPECIFICATIONS

SS-240CNS-300BHT CC DRIVER

Model: SS-240CNS-300BHT

Power: 240W

Rev.: V01

Release date: 2026-05-21



SS-240CNS-300BHT LED DRIVER

Features

- Efficiency up to 95%
- Isolated dimming: 0-10V, PWM, Resistor
- Optional aux: 12V/0.2A
- Time-controlled programmable
- Dim to off
- Protections: SCP/OTP/OVP/UVP
- Compatible with intelligent emergency controls
- Wide output voltage range, Dial Power Range Programmable
- IP65
- Surge protection: CM: 6kV, DM: 6kV
- Long lifetime
- Warranty: 5 years



IP65

Description

SS-240CNS-300BHT series is 240W round non-isolated constant current LED driver. This series of products have the advantages of isolated dimming function, ultra-high efficiency, compact housing, fully potted, compatible with intelligent emergency control, good heat dissipation and waterproof performance, high reliability, high cost-effective and so on.

Applications:

industrial and mining lights, sports lighting

Model List

Model	AC Input Range	Max. Pout	Vout Range	Recommended Voltage	Iout	Default Current	THD (Typ.)	PF (Typ.)	Eff. (Typ.)	Max.Tc
SS-240CNS-300BHT	180-528Vac	240W	180-300V	200V-300V	0.3-1.2A	0.96A	7%	0.97	95%	90°C

Note:

1.Default Tested:at220Vac,fullload, Ta 25°C.

2.The performance of the LED Driver can be guaranteed within the full power Vo range.The voltage lower than full power Vo range, it is need to test the performance with the LED module.

SS-240CNS-300BHT LED DRIVER

Input Characteristics

Parameter	Min.	Typ.	Max.	Remark
Rated AC Input Range	277Vac		480Vac	
AC Input Range	180Vac		528Vac	Reference derating curve
Input DC Voltage Range	280Vdc		500Vdc	
Input Frequency Range	47Hz	50/60Hz	63Hz	
Max Input Current			1.25A	277Vac, Full load
Max Input Power			275W	277Vac, Full load
Max Inrush Current(277Vac)			100A	Cold start
Max Inrush Current(347Vac)			120A	Cold start
Max Inrush Current(480Vac)			150A	Cold start
Standby Power			1.5W	480Vac, Dim-to-of
Power Factor	0.95	0.97		277-480Vac, Full load
	0.90			277-480Vac,70%-100% load
THD		7%	10%	277-480Vac, Full load
			20%	277-480Vac,70%-100% load

SS-240CNS-300BHT LED DRIVER

DIP switches:

Dial to adjust power+Dial to adjust color temperature+Dial to adjust angle

ANG	CCT	Power
SA	WW	150W
MA	NW	200W
BA	CW	240W

CW: cool light NW: mixed light WW: warm light
SA: small angle MA: medium angle BA: large angle

Structural Appearance

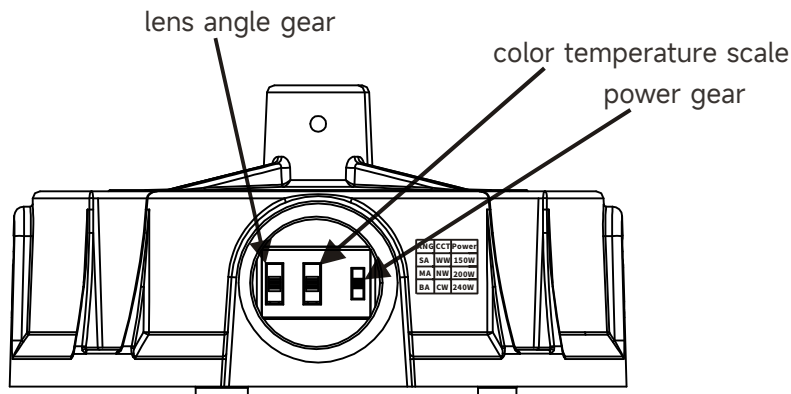

As shown in the figure, the color temperature from top to bottom: WW, NW, CW (warm light, mixed light, cold light) Lens angle gear from top to bottom: SA, MA, BA (small angle, medium angle, large angle) power gear from top to bottom: gradually larger

Note:

- 1.the schematic diagram for the default power level, programmable custom dial power level.
- 2.adjust the angle, adjust the power and color temperature need to be input after power failure operation.

SS-240CNS-300BHT LED DRIVER

Instructions for use of the BHT series triple-dial code:

Wiring method.

Red VOUT1+, Brown VOUT2+, Blue VOUT1-, Black VOUT2-

The dialing schematic diagram illustrates.

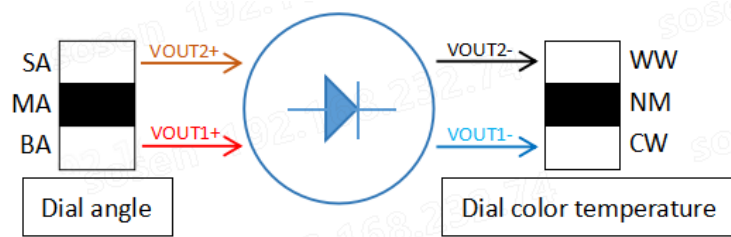

Output positive electrode	Output negative pole	Output state	Angle state	color temperature state
VOUT1+	VOUT1-	ON	BA	CW
VOUT1+	VOUT2-	ON	BA	WW
VOUT1+	VOUT1-&VOUT2-	ON	BA	NW
VOUT2+	VOUT1-	ON	SA	CW
VOUT2+	VOUT2-	ON	SA	WW
VOUT2+	VOUT1-&VOUT2-	ON	SA	NW
VOUT1+&VOUT2+	VOUT1-	ON	MA	CW
VOUT1+&VOUT2+	VOUT2-	ON	MA	WW
VOUT1+&VOUT2+	VOUT1-&VOUT2-	ON	MA	NW

SS-240CNS-300BHT LED DRIVER

Output Characteristics

Parameter	Min.	Typ.	Max.	Remark
O/P Voltage Range	180V		300V	Power derated @180-200V
Rated O/P Voltage	200V		300V	Po=Vo*Io=240W, Full load
Rated O/P Current	0.8A		1.2A	1.2A for 200V,0.8A for 300V
Adj. O/P Current (AOC)Range	0.8A	0.96A	1.2A	Current accuracy ±5%
	0.67A	0.8A	1.0A	
	0.5A	0.6A	0.75A	
No Load Voltage			350V	
Efficiency @277Vac	93.0%	95.0%		Output 300V/0.8A
Efficiency @347Vac	93.0%	95.0%		Output 300V/0.8A
Efficiency @480Vac	93.0%	95.0%		Output 300V/0.8A
O/P Current Tolerance	-5%		+5%	0.8A~1.2A
O/P Current Ripple(PK-AV)		5%	10%	Full load
Start-up Current Overshoot			10%	Full load
Start-up Time			0.5S	277-480Vac
Line Regulation	-3%		+3%	Full load
Load Regulation	-5%		+5%	
Temperature Coefficient	-0.06%/°C		+0.06%/°C	Tc:0°C~90°C
OTP	90°C	93°C	96°C	Drop current when OTP, and it can be automatically restored after the abnormality is removed.
Short Circuit Protection				Driver will not be damaged

SS-240CNS-300BHT LED DRIVER

Other Characteristics

Parameter		Min.	Typ.	Max.	Remark
AUX Power (Optional)	O/P Voltage	10.8V	12V	13.8V	
	O/P Current			200mA	
0-10V positive logic Dimming (Optional)	Dim Vmax	0V		12V	Negative dimming by programming
	Dim Range	10%loset		100%loset	DIM+ source current 110uA .
	Rec.Dim Range	0V		10V	Dimming prohibits reverse connection.
10-0V Negative Dimming (Optional)	Rec.Dim Range	0V		12V	DIM+ sink current I _{max} 40uA. Dimming prohibits reverse connection Programmable to 5-0V
PWM Dimming (Optional)	PWM High	9.8V		10.2V	DIM+ source current 110uA.
	PWM Low	0V		0.3V	Dimming prohibits reverse connection
	Frequency	1KHz		2KHz	
	PWM Duty	0%		100%	
Resistor Dimming (Optional)	Resistance	0Kohm		100Kohm	DIM+ source current 110uA.
	Dim Range	10%lomax		100%loset	
0-10V Dim to Off	Dim-off	0.6V	0.7V	0.8V	By DC voltage, PWM,dimming ratio
	Dim-on	0.8V	0.9V	1.0V	By DC voltage, PWM,dimming ratio
10-0V Dim to Off	Dim-off	9.0V	9.2V	9.4V	By DC voltage, PWM,dimming ratio
	Dim-on	8.8V	9.0V	9.2V	By DC voltage, PWM,dimming ratio

SS-240CNS-300BHT LED DRIVER

Other Characteristics

Parameter	Min.	Typ.	Max.	Remark	
Intelligent Emergency Control (Optional, off by default)	Emergency switchover time	3S		AC power failure switching to battery power supply time	
	Output Current		8%	10%	Emergency output current can be set via PC software
	Auto-exit time			2H	When the sensor does not detect a signal configurable
	Access to emergency communications	4Hz duty cycle 25%, high level: 4-10V, low level: 0-0.3V			Duration 30S
	Withdrawal from emergency communications	1Hz duty cycle 25%, high level: 4-10V, low level: 0-0.3V			Duration 2H; configurable
Timing Curve(Optional)	By programming			Set by program	
Lifetime(Tc≤85°C)	≥50,000 hours			80% load	
MTBF	198,000 hours			220Vac, Full load, Ta=25°C (MIL-HDBK-217F)	
Protection class	IP65				
Tc	90°C				
Warranty	5 years			Tc 85°C	
Net Weight	880g			Input line: 300mm	
Dimension	Φ128mm*62.5mm			WxH	

NOTE: All the parameters above are tested Ta 25°C and LED load, unless specified.

SS-240CNS-300BHT LED DRIVER

Environmental Requirements

Parameter	Min.	Typ.	Max.	Remark
Operating Temperature(Tcase)	-40°C	25°C	+90°C	
Storage Temperature	-40°C	25°C	+90°C	
Operation Humidity	10%RH		90%RH	
Storage Humidity	5%RH		95%RH	
Altitude	-65m		4000m	

Safety and EMI/EMS Standards

Certification	Standard	Status	Remark
UL/cUL	UL8750 CSA C22.2 No. 250.13	✓	
ENEC	EN 61347-1 EN 61347-2-13 EN IEC 62384		
RCM	AS/NZS61347.2.13		
CCC	GB/T 19510.1 GB/T 19510.213		
CE	EN 61347-2-13 EN61347-1		

EMI/EMS	Criterion	Remark
Conduction Emission	FCC Part 15 Subpart B; ANSI C63.4	Class A
Radiation Emission	FCC Part 15 Subpart B; ANSI C63.4	Class A
Harmonic Current Emissions	EN/IEC 61000-3-2	Class C
Surge	ANSI/C82.77-5	DM: 6kV,CM: 6kV,Criterion B
Ring Wave	ANSI/C82.77-5	DM: 6kV,CM: 6kV,Criterion B

SS-240CNS-300BHT LED DRIVER

Safety Test Items

Safety Test Items	Technical Indicators			Remark
Insulation Requirements	UL Insulation Requirements	TUV Insulation Requirements	CCC Insulation Requirements	
Input-Case	2U+1000Vac	/	/	Basic insulation
Input-Dim	2U+1000Vac	/	/	Basic insulation
Dim-Case	500Vac	/	/	Basic insulation
Insulation Resistance	$\geq 10M\Omega$			Input-Dim, Test voltage:500Vdc
Ground Resistance	$\leq 0.1\Omega$			25A/1min
Leakage Current	$\leq 0.75mA$			480Vac

Note:

1. The power supply complies with the relevant EMC standards. The power supply, as part of the terminal equipment system, needs to be combined with the whole system to reconfirm EMC.
2. During voltage withstand test, please short-circuit between L/N, short-circuit between positive/negative output line, and short-circuit between positive/negative dimmer line and auxiliary power supply.

Performance Curves

Input Inrush Current

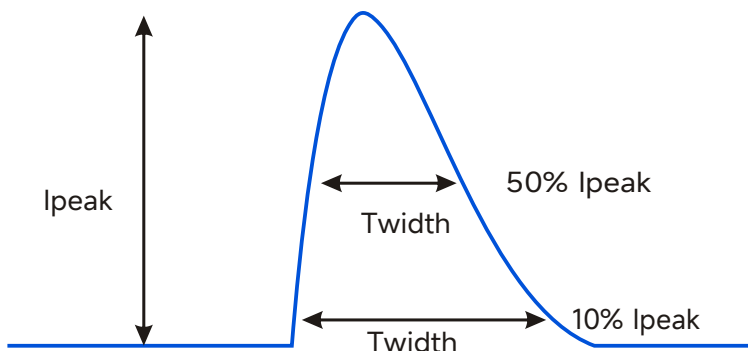

V_{in}	I_{peak}	T(@10% of I_{peak})	T(@50% of I_{peak})
277Vac	100A	650uS	200uS
347Vac	120A	400uS	250uS
480Vac	150A	650uS	200uS

SS-240CNS-300BHT LED DRIVER

Performance Curves

Output Voltage Vs. Output Current(Dim/AOC Window)

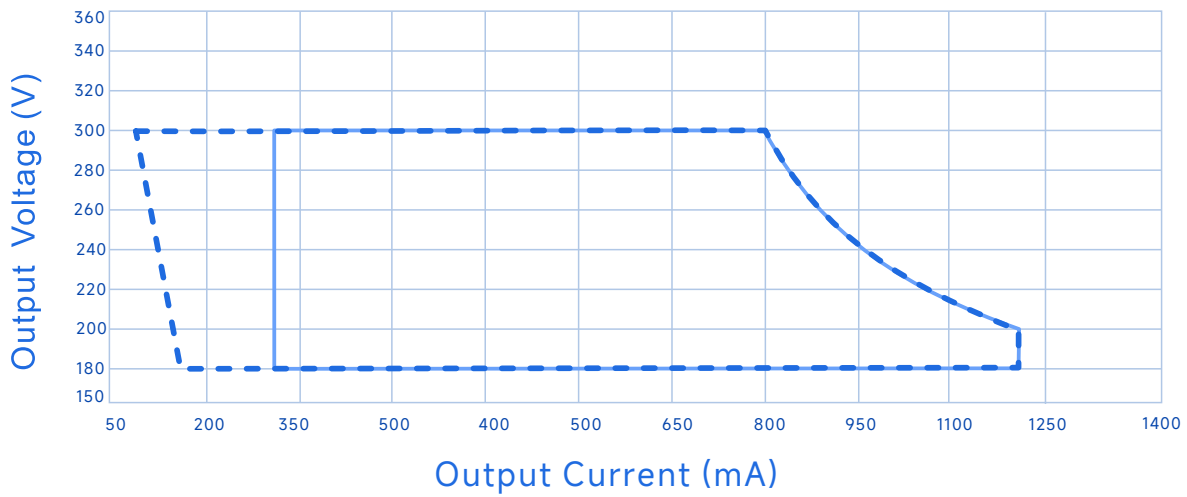

----- Dimming Window ————— AOC Window

Efficiency Vs. Output Voltage($V_{in}=120V_{ac}$)

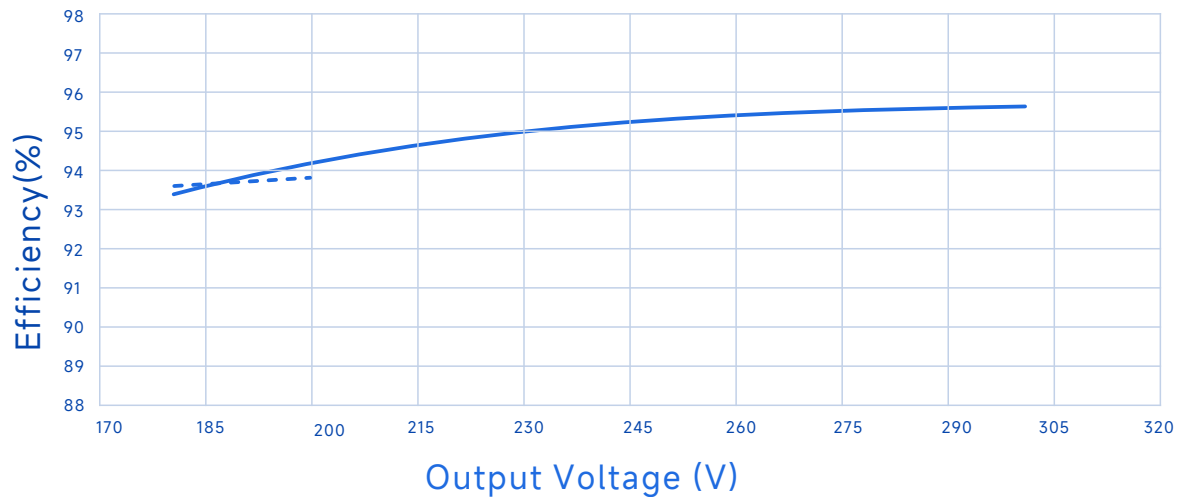

----- $I_o=1200mA$ ————— $I_o=800mA$

SS-240CNS-300BHT LED DRIVER

Performance Curves

Efficiency Vs. Output Voltage ($V_{in}=277V_{ac}$)

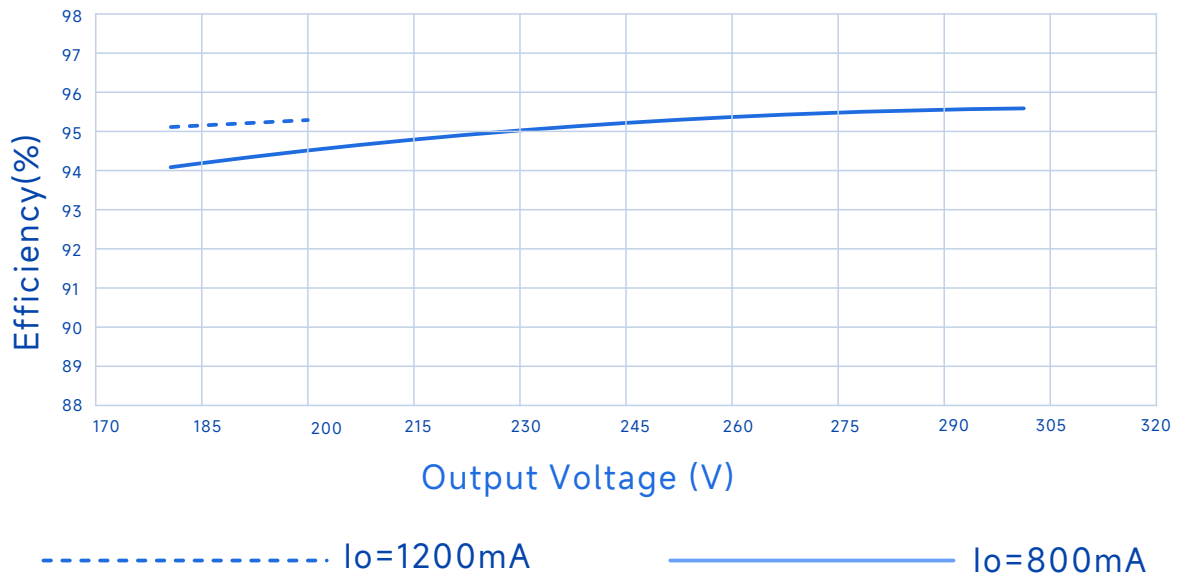

Efficiency Vs. Output Voltage ($V_{in}=347V_{ac}$)

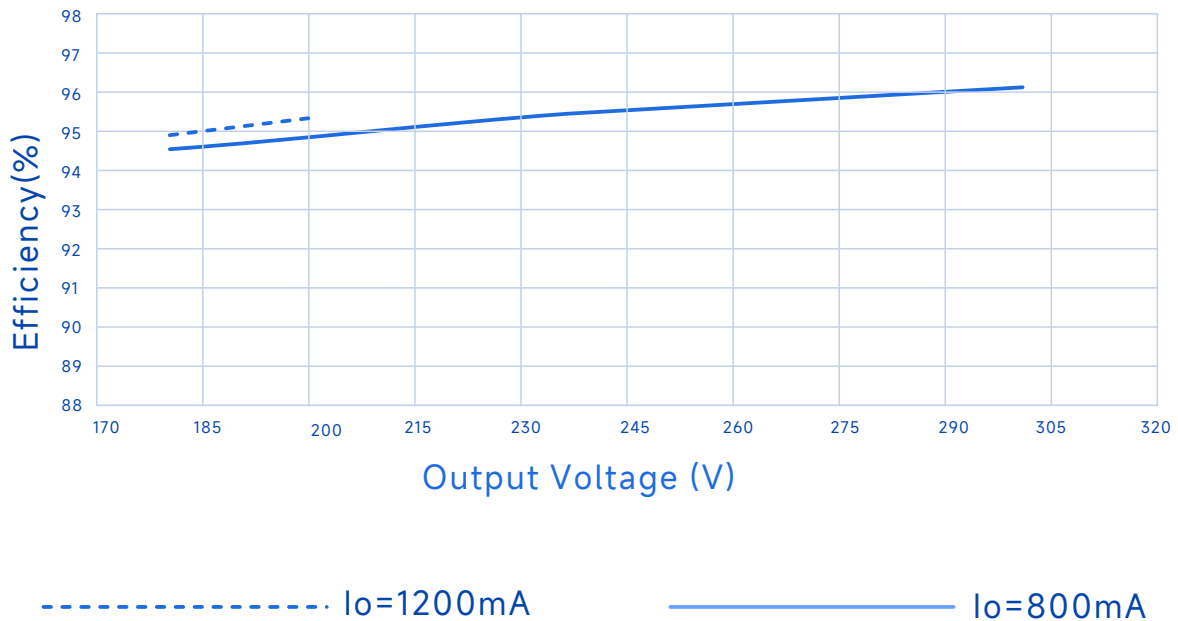

SS-240CNS-300BHT LED DRIVER

Performance Curves

Power Factor Vs. Output Power

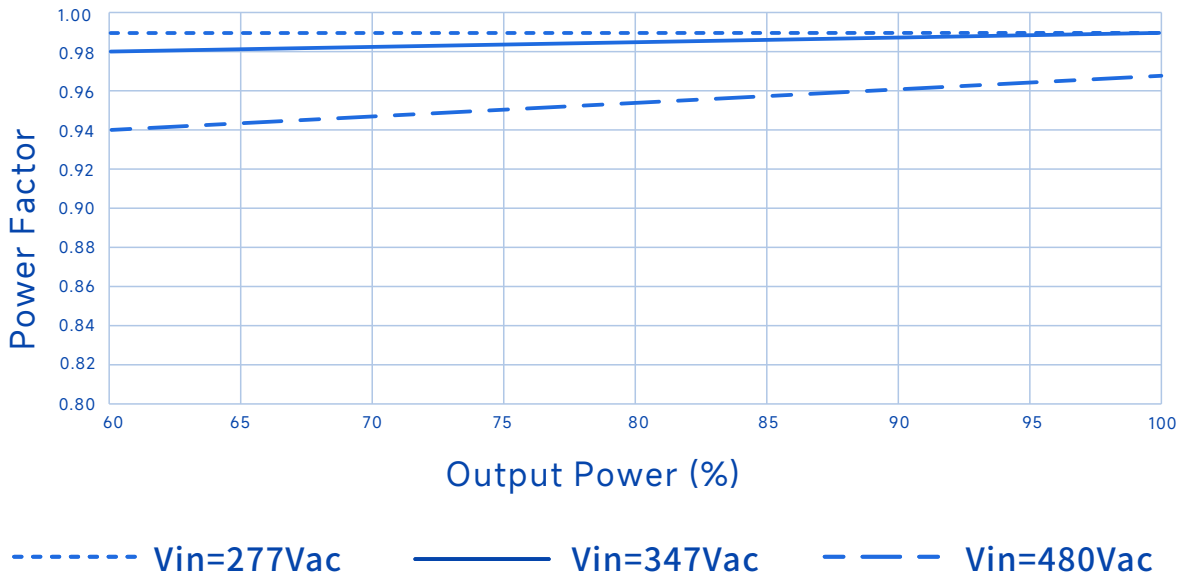

THD Vs. Output Power

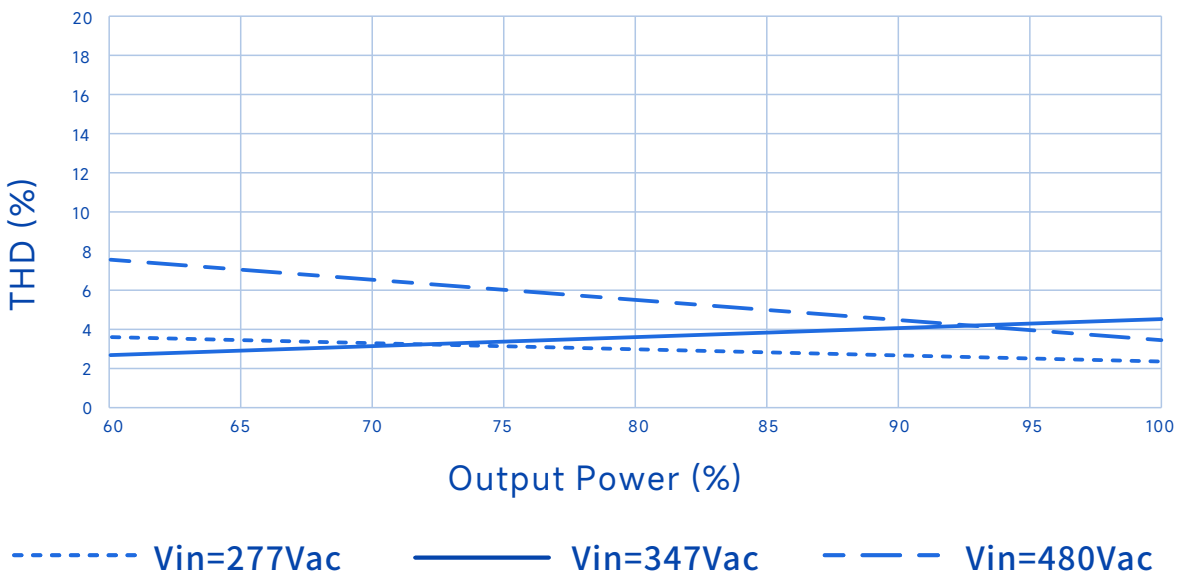

SS-240CNS-300BHT LED DRIVER

Performance Curves

Output Power Vs. Input Voltage

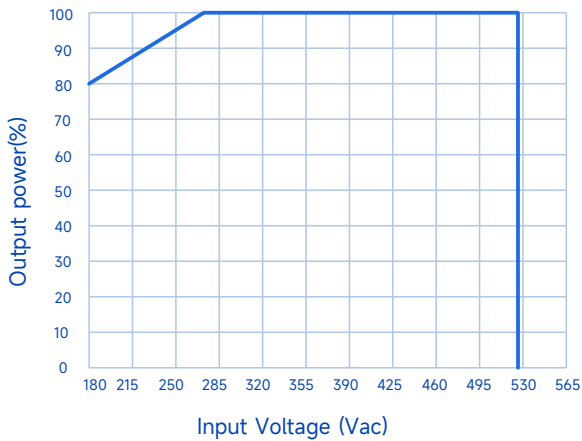

Output Power Vs. Case Temperature

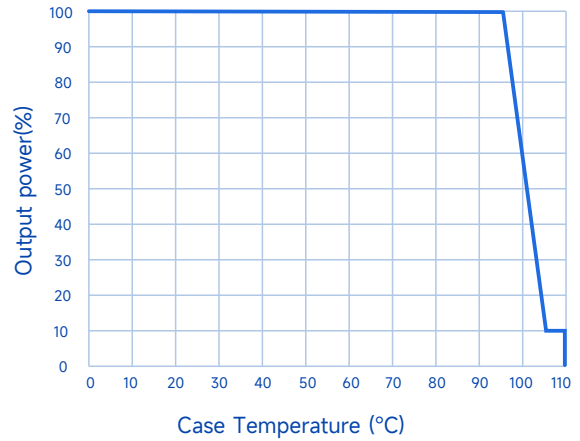

Output Power Vs. Dimming

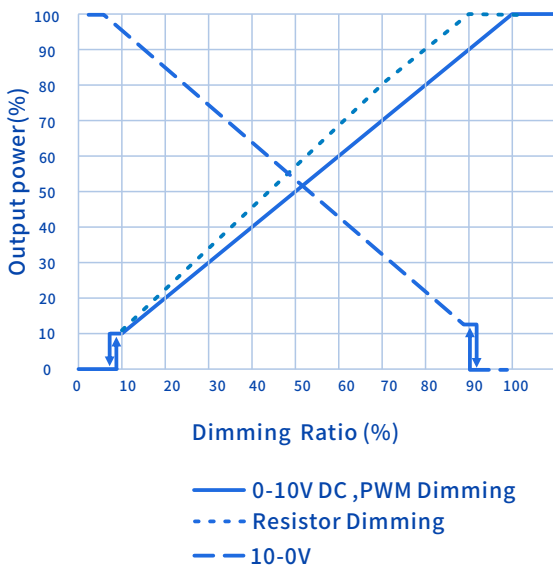

Lifetime Vs. Case Temperature

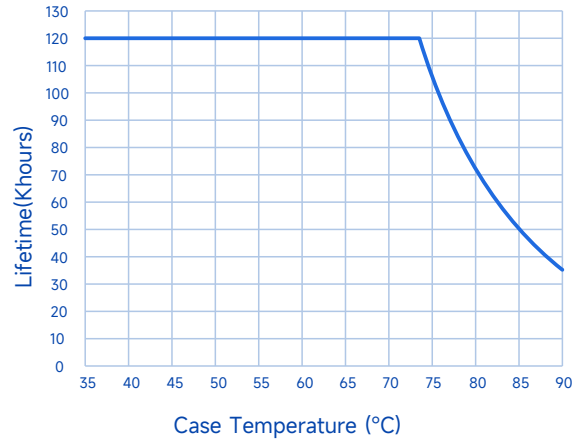

SS-240CNS-300BHT LED DRIVER

Programming connection diagram

Legacy Timer: Driver's O/P follows the pre-programmed timing curve after turn-on.

Auto-Adjust by Percentage: Driver's O/P will be adjusted by automatically changed dimming curve by the period percentage based on the latest 5 dimming curve.

Auto-Adjust by Mid-point: Driver's O/P will be adjusted by automatically changed dimming curve by mid-point based on the latest 5 dimming curve.

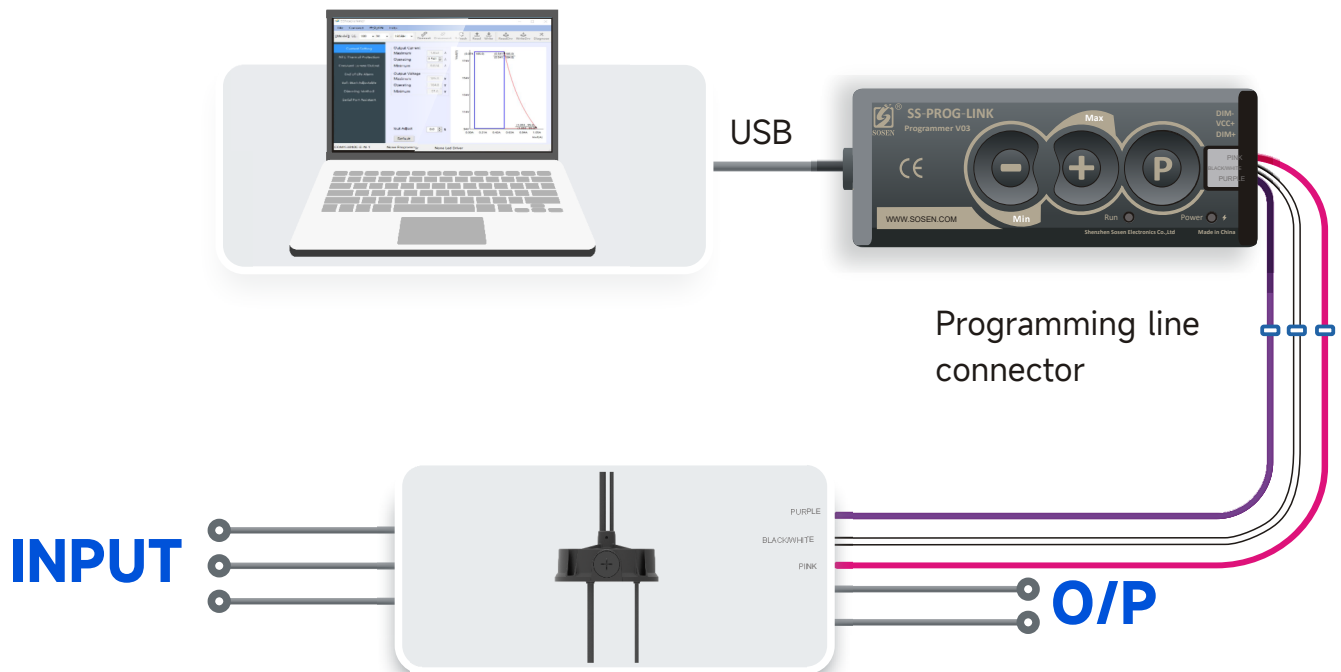

Note:

During the lifetime of the LED lamp, the driver continuously adjusts to increase the output optical power, thus ensuring that the LED lamp still has a constant optical power output after a long period of operation.

SS-240CNS-300BHT LED DRIVER

Mechanical Characteristic

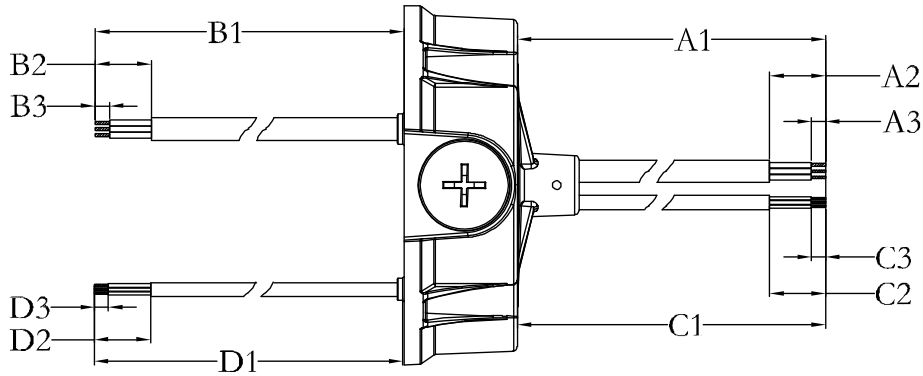

Optional wires	AC Input Cable (mm)			DC output Cable mm			UP Dimming Cable mm			Down Dimming Cable mm		
	kind	A1	A2	A3	B1	B2	B3	C1	C2	C3	D1	D2
3#	300±10	45±5	10±2	200±10	22±3	9±1	300±10	45±5	10±2	200±10	22±3	9±1

AC Input Cable	DC output Cable	UP Dimming Cable	Down Dimming Cable
UL: SJTW, 3*17AWG, Black: ACL, White: ACN, Green: \oplus ;	Global: SJOW, 4*17AWG, Red: V1+(Large angle); Brown: V2+ (Small angle); Blue: V1- (Cool light); Black: V2- (Warm light);	BHT: UL 21996 3*22AWG Purple: DIM+, Pink: DIM- Black/White: Vaux+;	UL/EU/Global : UL 21996 3*22AWG Purple: DIM+, Pink: DIM- Black/White: Vaux+;

SS-240CNS-300BHT LED DRIVER

Mechanical Characteristic

Name Description	Standard Code	mm(In.)
Fixing screw hole diameter	4-B	Φ6.5(0.26)
Housing Diameter	D	Φ128(5.04)
Enclosure height	H	62.5(2.46)
Eyelet hole (optional)	Z	M10*1.5(depth18mm) G1/2(depth18mm)
Eyebolt Holes	R	M4*0.7
Mounting hole size	W	113(4.45)
Tc point location	Y	32(1.26)

Note

1, Please follow the "LED Driver User Manual" obtained from SOSEN's official website for assembly.

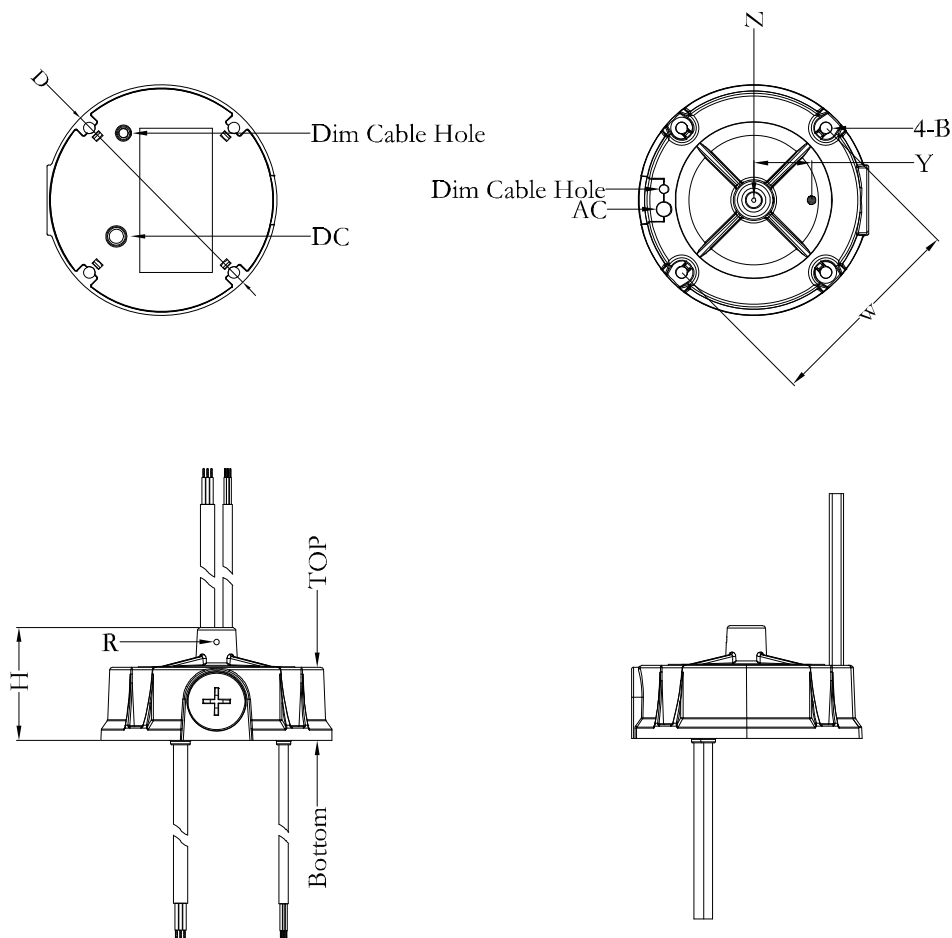

SS-240CNS-300BHT LED DRIVER



Assembly Tips

- 1.If the product has an external adjustable potentiometer, please adjust the current, it is recommended to use 704 silicone to adjust the current of the Seal the hole of adjusting current with 704 silicone and cover it with waterproof rubber plug.
- 2.When the dimmer line is not in use, please seal the connector of the dimmer line with insulating sleeve, so as not to string into the interfering signals and cause damage to the dimmer line, affecting the power supply. dimming line damage, affecting the normal operation of the power supply.
- 3.The trace routing on aluminum substrates is designed in compliance with creepage distance requirements specified by relevant certification regulations.
- 4.The creepage distance between LED+ and LED- on the aluminum substrate is designed in compliance with the relevant certification regulations.
5. aluminum substrate to minimize the laying of copper area, reduce junction capacitance, reduce leakage current.
6. LED lamp bead arrangement is recommended first and then string.
7. LED light board insulation level should meet the reliability design requirements.
8. other notes, please refer to the “LED driver power supply instruction manual”.

Warning

Insufficient or compromised insulation voltage resistance in LED light panels may cause breakdown and short circuits to earth, resulting in damage to the luminaire and LED driver, and posing significant safety hazards. It is recommended to install a residual current device (RCD) during application.

Package

- Outside carton dimension: L×W×H =577mm×385mm×162mm;
- 15PCS/Carton;
- Net weight/Piece: 0.88kg;Gross weight/Carton: 14.24kg;
- Please refer to the product name, model number, manufacturer identification, QC PASS, manufacturing date on the package.

Transportation

Packaging is designed suitable for transportation by trucks, vessels and flights. The products should be avoided direct sunlight and rain, loaded/unloaded with caution.

Storage

The product storage meets the standard of the GB 3873 83.
Products should be rechecked if stored for over 1 year before assembly.

RoHS

Products comply with RoHS Directive (2011/65/EU) and amendment 2015/863/EU.

Revision History

Version	Description of Update	Updated Date	Remark
V00	Original Release	2026/04/23	
V01	Update Input DC Voltage Range	2026/05/21	